

# STELTEC

V4.1-2025-08



**BU 5220**

## Basic-L1 Operation Manual

This Manual introduces Basic-L1 from STELTEC.

Basic-L1 is a Low-voltage Lithium-ion Phosphate Battery storage system

Please read this manual before you install the battery and follow the instruction carefully during the installation process.

## CONTENTS



<b>1. Technical Data</b>	1-2
<b>2. Safety Information</b>	
2.1 General Safety	3
2.2 Personal Safety	3-4
2.3 Electrical Safety	4-6
2.4 Transportation Safety	6
<b>3. Product Overview</b>	
3.1 Brief Introduction	7
3.2 Interface Introduction	8
3.2.1 Switch ON/OFF	8-9
3.2.2 LED Indicator Definition	9-10
3.2.3 CAN / RS485 Port	10
3.3.4 RS232 Port	10
<b>4. Installation guide</b>	
4.1 Checking Before Installation	11
4.1.1 Checking Outer Packing Materials	11
4.1.2 Checking Deliverables	11
4.2 Tools	13
4.3 Installation environment requirements	13
4.3.1 Installation carrier requirements	13
4.4 Installation Instructions	14
4.4.1 Dimensions	14
4.4.2 Installation Procedure (Rack Mounted)	15-16
4.4.3 Wiring Steps	17-18
<b>5. Commissioning Procedure</b>	19
<b>6. Maintenance</b>	
6.1 Recharge Requirements During Normal Storage	20
6.2 Recharge Requirements When Over Discharged	20

## 1. Technical Specification



<b>Product Type</b>	<b>Basic-L1</b>
<b>Battery Model</b>	BU-5220
<b>Battery System Capacity</b>	5.22kWh
<b>Cell Technology</b>	Li-ion(LFP)
<b>Battery Cell Capacity</b>	102Ah
<b>Configuration</b>	1P16S
<b>Nominal Voltage</b>	51.2V
<b>Operating Voltage Range</b>	45.6~56.2V
<b>Dimension(W*D*H)</b>	440*550*130(mm)
<b>Net Weight</b>	46kg
<b>Scalability</b>	Max. 15 systems in parallel operation
<b>Installation</b>	Floor stand
<b>Depth of Discharge</b>	90%
<b>Charge/Discharge Current(Recommended)</b>	50A
<b>Charge/Discharge Current(Max)</b>	100A
<b>Cooling Method</b>	Natural convection
<b>Communication Port</b>	RS232, RS485, CAN
<b>Protection Class</b>	IP20
<b>Environment</b>	Indoor
<b>Operating Temperature</b>	0°C~50°C
<b>Shelf Temperature</b>	-20°C~50°C
<b>Humidity</b>	5%-95%
<b>Max. Operating Altitude</b>	2,500m
<b>Certificates</b>	IEC62619 / IEC61000 / CE / UN38.3 / MSDS



## 2.Safety Information

### 2.1 General Safety

Please carefully read the manual safety precautions and observe all the safety instructions on the equipment and in this document.

The "DANGER", "WARNING", and "NOTICE" statements in this document do not cover all the safety instructions. They are only supplements to the safety instructions.

For user safety and utilization efficiency of this manual, a list of symbols is designed to alert people from danger. You must understand and comply with the emphasized information to avoid personal injury and property damage. Relative safety symbols have been listed below.

 <b>Danger</b>	DANGER indicates a hazardous situation which, if not avoided will result in serious injury and/or fire.
 <b>Warning</b>	WARNING indicates a hazardous situation which, if not avoided, will result in property loss and/or void the warranty.
 <b>NOTICE</b>	NOTICE indicates normal situation which, if not avoided, will result in damage to the battery.

### NOTICE

Follow local laws and regulations when installing, operating, or maintaining the equipment. The safety instructions in this document are only supplements to local laws and regulations.

### 2.2 Personal Safety

#### Personal Requirements

People who plan to install or maintain battery equipment must be trained, understand all necessary safety precautions, and are able to correctly perform all operations.

Only qualified professionals or trained people are allowed to install, operate, and maintain the equipment.







### **▲ DANGER**

- Do not place battery in an area accessible by children or pets.
- Do not touch the energized battery, the temperature of the battery enclosure may increase during operation.
- Do not touch the energized battery terminals.
- Do not stand on, lean on, or sit on the battery.

### 2.3 Electrical Safety

#### Symbols on Battery

There are some electrical symbols on battery relate to electrical safety. Please make sure you have fully understood them before installation.

	Electrical danger	Voltage exists when the battery is powered on. Only qualified engineers are allowed to operate.
	Earth connector	Earth connection.
	DC positive and negative connectors	Identify positive and negative connectors of DC power source.
	CE mark	The product meets CE certification.
	WEEEtag	Batteries must not be disposed with general waste. It must be appropriately recycled in accordance with local regulations.
	Recycle	Batteries can be recycled, please refer to your local regulations regarding the correct disposal methods.

## Electrical Safety

### **⚠ DANGER**

- Before installation, ensure that the equipment is intact. Otherwise, electric shocks or fire may occur.
- Do not connect or disconnect power cables when battery is power-on. Which may cause electric arcs and sparks more over fire or personal injury.
- Before connecting a power cable, check the positive or negative connectors are correct.
- Do not parallel connection with different batteries.
- Do not connect battery with AC directly.
- Do not connect battery with PV wiring directly.
- Do not connect battery to faulty or unqualified inverter or charger.
- Do not create short circuits with the external connection.
- Make sure the grid is cut off and the battery is powered off before maintenance.
- Make sure the earth cable is connected correctly before operation.

### **⚠ WARNING**

- Recharge battery in every six months if not in use.
- Recharge battery within 10 days after battery is fully discharged(SOC=0%).
- Ensure battery cable is installed correctly.
- When the battery is being installed or repaired, ensure the battery is powered off and and isolated. Using a multimeter check to ensure there is no voltage in the positive and negative terminals.

### **⚠ CAUTION**

- Please use appropriately insulated tools for installation and maintenance.
- Please check the LED status when the battery is powered on.
  
- Please ensure the communication cable is connected correctly between the battery and the inverter.
- Please check for inverter alarms and the SOC reading once communication is established between the inverter and the battery.

## Environment Safety

### **⚠ WARNING**

- Ensure the battery is installed in a dry and well-ventilated location.
- The installation position must be away from direct sunlight and rain.
- The installation position must be far away from potential sources of fire..
- The installation position must be far away from all sources of water.
- Do not install the equipment in locations that contain flammable gases and/or flammable liquids.
- The operation and service life of the battery depends on the operating temperature. Operate the battery at a temperature equal to or better than the ambient temperature. The recommended operating temperature range is from 0°C to 30°C.

## 2.4 Transportation Safety

### **⚠ WARNING**

- The products have passed UN38.3 certification.
- The products have MSDS documents available.
- The products belong to class 9 dangerous goods.
- **Please protect the packing case from the below situations:**
  - Being dampened by rains, snows, or falling into water.
  - Falling down or mechanical impact.
  - Being upside-down or tilted.

## 3.PRODUCT OVERVIEW

### 3.1 Brief Introduction



PRODUCT OVERVIEW

Basic-L1 is a lithium battery with an operating voltage range between 45.6~56.2V. It is designed for residential energy storage applications and works together with a low voltage hybrid inverter. **Basic-L1 is not suitable for supporting life-sustaining medical devices.**

Basic-L1 has built-in BMS (Battery Management System), which can manage and monitor cells information including voltage, current and temperature. Besides that, BMS can balance cells charging to extend cycle life. BMS has protection functions including over-discharge, over-charge, over-current and high/low temperature; the system can automatically manage charge state, discharge state and balance state.

Multiple Basic-L1 can be connected in parallel to expand capacity and power, 15 Basic-L1 can be connected in parallel at most.

**Note: For multiple batteries in parallel, only the Master battery SOC LED will be on to show the whole system SOC level, slave battery SOC LEDs are off, but the Normal&Alarm LED will show normally.**

### 3.2 Interface Introduction

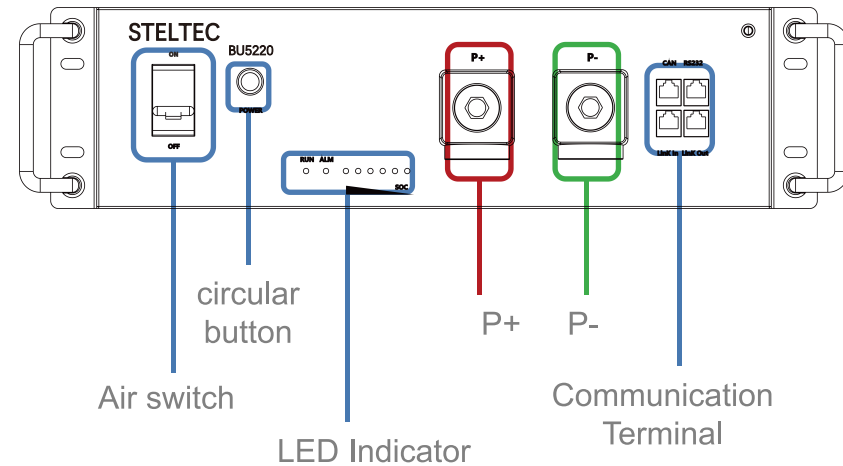

#### 3.2.1 Switch ON/OFF

##### 1. Switch ON

For single Battery Module, turn on the air switch, Long press (more than 3 seconds) ON/OFF button, Normal LED will be lighted in the front panel then battery will operate normally. L1 to L6 shows battery SOC, L7/L8 shows battery status.

For multiple Battery Modules in parallel, turn on the air switch of all batteries, long press (more than 3 seconds) ON/OFF button of master battery (Which connect with inverter), normal LED will be lighted, battery system will automatically encode and assign ID to each slave battery, then battery system will operate normally.

## 2. Switch OFF

For multiple Battery Modules in parallel, turn off the air switch of all batteries, press ON/OFF button of master battery (which connect with inverter) more than 3s, LED will flash in the front panel and then release the button, the master battery will shut down after all slave batteries shut down. (Sleep mode)

For single Battery Module, turn off the air switch, Long press (more than 3 seconds) ON/OFF button, LED will flash in the front panel and then release the button, the battery will shut down.

### 3.2.2 LED Indicator Definition

Note:

flash 1 - 0.25s light / 3.75s off

flash 2 - 0.5s light / 0.5s off

flash 3 - 0.5s light / 1.5s off

### LED Indicators Instructions

Status	RUN	ALM	Battery Level Indicator							Descriptions	
	L8	L7	L6	L5	L4	L3	L2	L1			
Shut down	OFF	OFF	OFF	OFF	OFF	OFF	OFF	OFF	OFF	All OFF	
Standby	Flash 1	OFF	According to the battery level							Indicates Standby	
Charging	Normal	Light	OFF	According to the battery level							The highest capacity indicator LED flashes (flash2), others lighting
	Full Charged	Light	OFF	Light	Light	Light	Light	Light	Light	Turn to standby status when charger off	
	Protection	OFF	Light	OFF	OFF	OFF	OFF	OFF	OFF	Stop charging	
Discharge	Normal	Flash 3	OFF	According to the battery level							
	UVP	OFF	OFF	OFF	OFF	OFF	OFF	OFF	OFF	Stop charging	
	Protection	OFF	Light	OFF	OFF	OFF	OFF	OFF	OFF	Stop discharge	
Fault	OFF	Light	OFF	OFF	OFF	OFF	OFF	OFF	OFF	Stop charging and Discharge	

### Charging Battery Level Indicators Instructions

Status	Charging									
	L8	L7	L6	L5	L4	L3	L2	L1		
Battery Level Indicator	●	●	●	●	●	●	●	●	●	
Battery Level %	0~17%	Light	OFF	OFF	OFF	OFF	OFF	OFF	Flash 2	
	18~33%			OFF	OFF	OFF	OFF	Flash 2	Light	
	34~50%			OFF	OFF	OFF	Flash 2	Light	Light	Light
	51~66%			OFF	OFF	Flash 2	Light	Light	Light	Light
	67~83%			OFF	FLASH 2	Light	Light	Light	Light	Light
	84~100%			Flash 2	Light	Light	Light	Light	Light	Light
	Full Charged			Light	Light	Light	Light	Light	Light	Light

### Discharging Battery Level Indicators Instructions

Status	Discharge									
	L8	L7	L6	L5	L4	L3	L2	L1		
Battery Level Indicator	●	●	●	●	●	●	●	●	●	
Battery Level %	0~17%	Flash 3	OFF	OFF	OFF	OFF	OFF	OFF	Light	
	18~33%			OFF	OFF	OFF	OFF	Light	Light	
	34~50%			OFF	OFF	OFF	Light	Light	Light	Light
	51~66%			OFF	OFF	Light	Light	Light	Light	Light
	67~83%			OFF	Light	Light	Light	Light	Light	Light
	84~100%			Light	Light	Light	Light	Light	Light	Light

### 3.2.3 CAN / RS485 Port

CAN / RS485 Communication Terminal (RJ45 port), connect to inverter, follow CAN / RS485 protocol.

PIN	Definition
Pin 1 Pin 8	RS485-B ( to PCS, reserved )
Pin 2 Pin 7	RS485-A ( to PCS, reserved )
Pin 3	NC
Pin 4	CANH ( to PCS )
Pin 5	CANL ( to PCS )
Pin 6	GND

### 3.2.4 RS232 Port

RS232 Communication Terminal (RJ45 port) follow RS232 protocol, for manufacturer or professional engineer to debug or service.

PIN	Definition
Pin 1 Pin 8	GND
Pin 2 Pin 7	RS232_TX
Pin 3 Pin 6	RS232_RX
Pin 4 Pin 5	NC

## 4.INSTALLATION GUIDE

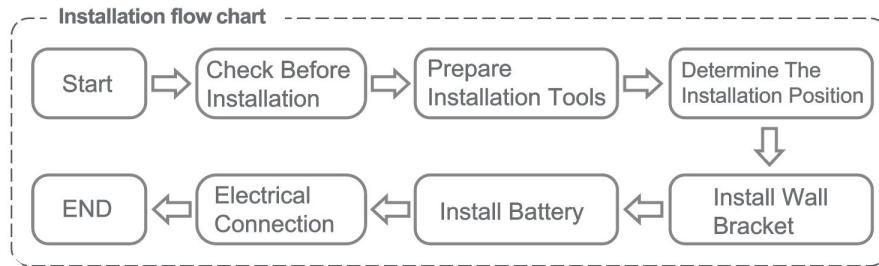

### 4.1 Checking Before Installation

















#### 4.1.1 Checking Outer Packing Materials

Packing materials and components may be damaged during transportation. Therefore, check the outer packing materials before installing the battery. Checking the surface of packing materials for damage, such as holes and cracks. If any damage is found, do not unpack the battery and contact the dealer as soon as possible.











#### 4.1.2 Checking Deliverables

After unpacking the battery, check whether deliverables are intact and complete. If any damage is found or any component is missed, contact the dealer.

The below table shows the components and mechanical parts that should be delivered.

STE-BU5220 packing list				
NO.	Part name/size	Quantity	Photo	Used for
1	Battery pack	1		
2	Stacking brackets	4		Stacking brackets
3	Power cord, SC25-8 at one end, SC25-10 at the other end, AWG4# silicone wire 3512, L=1500mm, Black color	1		output cable-
4	Power cord, SC25-8 at one end, SC25-10 at the other end, AWG4# silicone wire 3512, L=1500mm, Red color	1		output cable+
5	Cross countersunk head screws_thin head_M5*8mm_8.8 grade 304 stainless steel	12		To lock stacking bracket
6	Super five categories_RJ45 shielded crystal head	4		To remake the communication cable's crystal head when necessary.
7	V1.0_RJ45 crystal plug_Black Super Class 5 Unshielded_T568B color line sequence_Line length 160mm_RJ45 crystal plug	1		Communication cable for parallel of multiple packs
8	V1.0_RJ45 crystal plug_Black Super Class 5 Unshielded_Customized wire sequence 4 on 4_5 on 5_Line length 2000mm_RJ45 crystal plug	1		Communication cable between master pack and inverter
9	Red Nylon Tube Terminal_VE25-25_Purple Copper with Tin Plating	1		Accessory terminals
10	Black Nylon Tube Terminal_VE25-25_Purple Copper with Tin Plating	1		Accessory terminals
11	Flat gasket M8 * 20 * 1.5mm_8.8 grade 304 stainless steel	2		Accessory gasket
12	SC35-8_Purple Copper Tinned Terminals	2		Accessory terminals
13	SC25-8_Purple Copper Tinned Terminals	2		Accessory terminals
14	Yellow-green two-color grounding Cable	1		Grounding Cable
15	Screw Cross outer hexagon three combination screws_M6*12mm_8.8 grade 304 stainless steel	1		Grounding screw
16	Outgoing Inspection Report	1		Outgoing Inspection Report
17	2g moisture-proof desiccant	2		Moisture-proof

## 4.2 Tools

Tools			
Installation	Knife 	Measuring tape 	Socket wrench (10/16mm) 
	Rubber mallet 	Cross Screwdriver 	Hammer drill (12mm) 
Protection	ESD gloves 	Safety goggles 	Anti-dust respirator 
	Safety shoes 		

## 4.3 Installation environment requirements

- Install the battery in the indoor environment.
- Place battery in secure location away from children and animals.
- Do not place the battery near any heat sources and avoid sparks.
- Do not expose the battery to moisture or liquids.
- Do not expose the battery to direct sunlight.

### 4.3.1 Installation carrier requirements

- Only mount battery on fire resistant building. Do not install batteries on flammable buildings.
- Battery is quite heavy, make sure the wall/ground can meet the load bearing requirements.

## 4.4 Installation Instructions

### 4.4.1 Dimensions

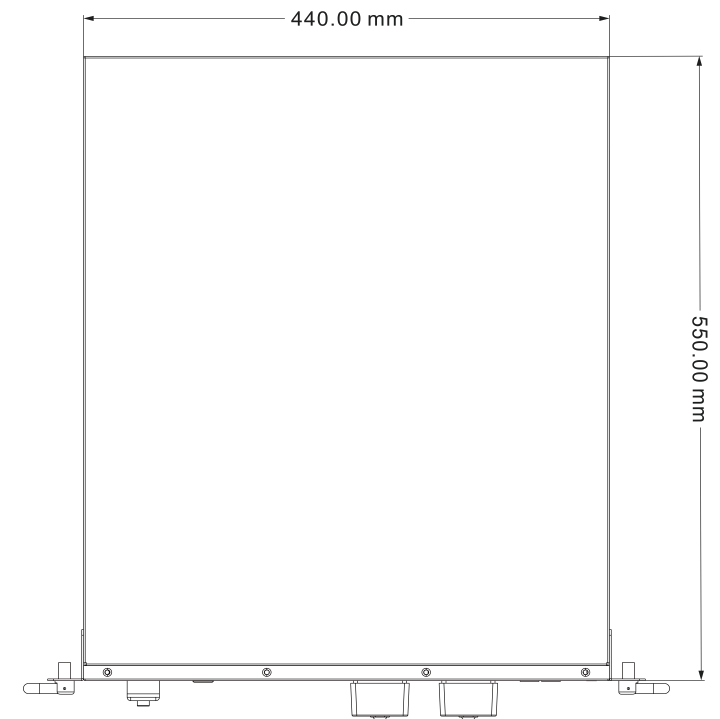
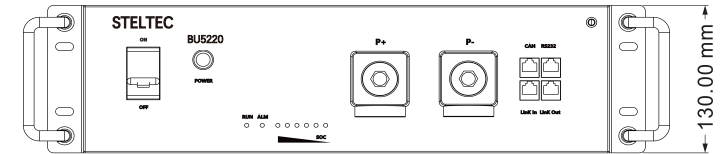

## 4.4.2 Installation Procedure (Rack Mounted)

### STEP 1

Remove the Handles from the battery.

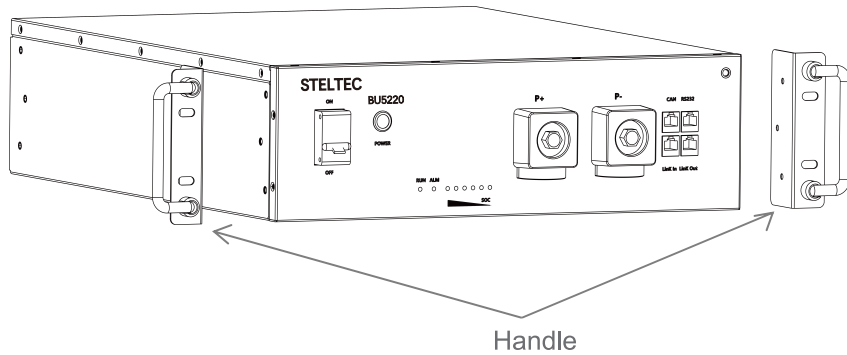

### STEP 2

Install Stacking brackets at the four corners of the battery.

Stacking brackets(M4\*8)

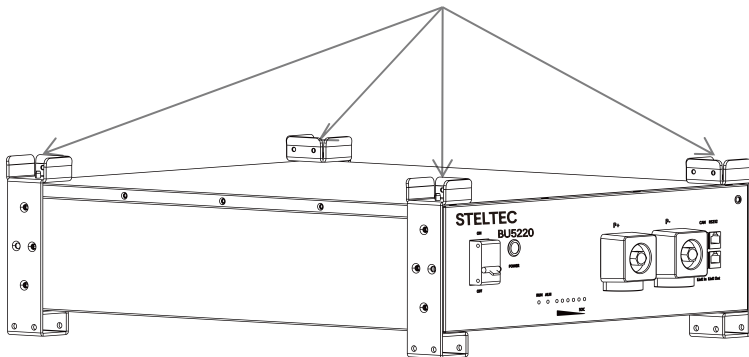

### STEP 3

The battery with the Stacking brackets is stacked like below.

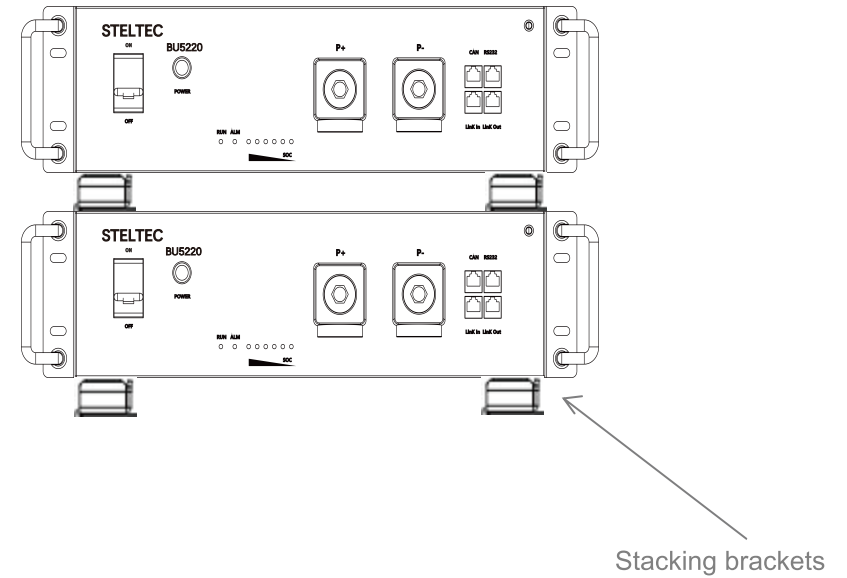

## 4.4.3 Wiring Steps

### STEP 1

Connected to ground.

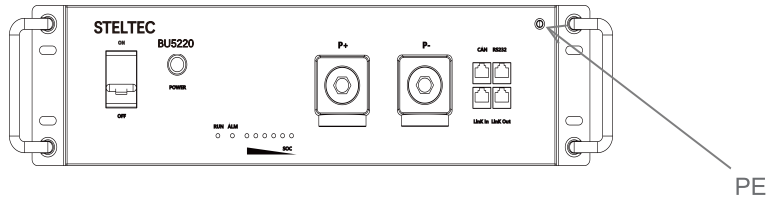

### STEP 2

Connecting power cables.

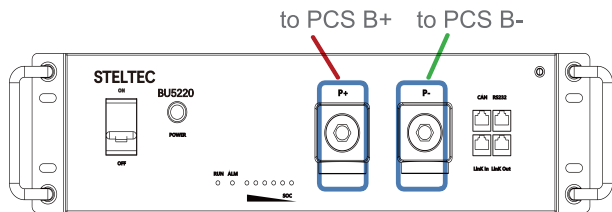

### STEP 3

Connect the communication cable.

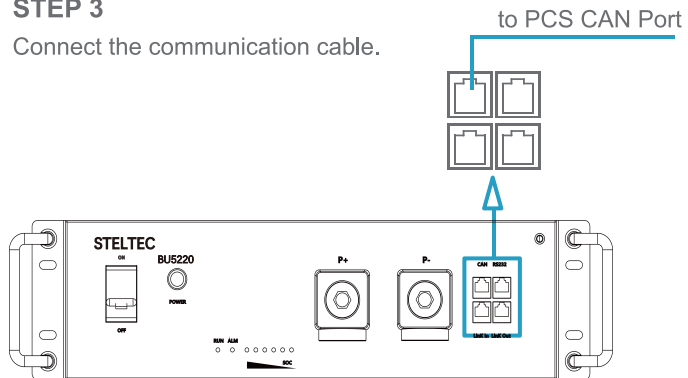

### STEP 4

When multiple batteries are connected in parallel, follow the following wiring mode.

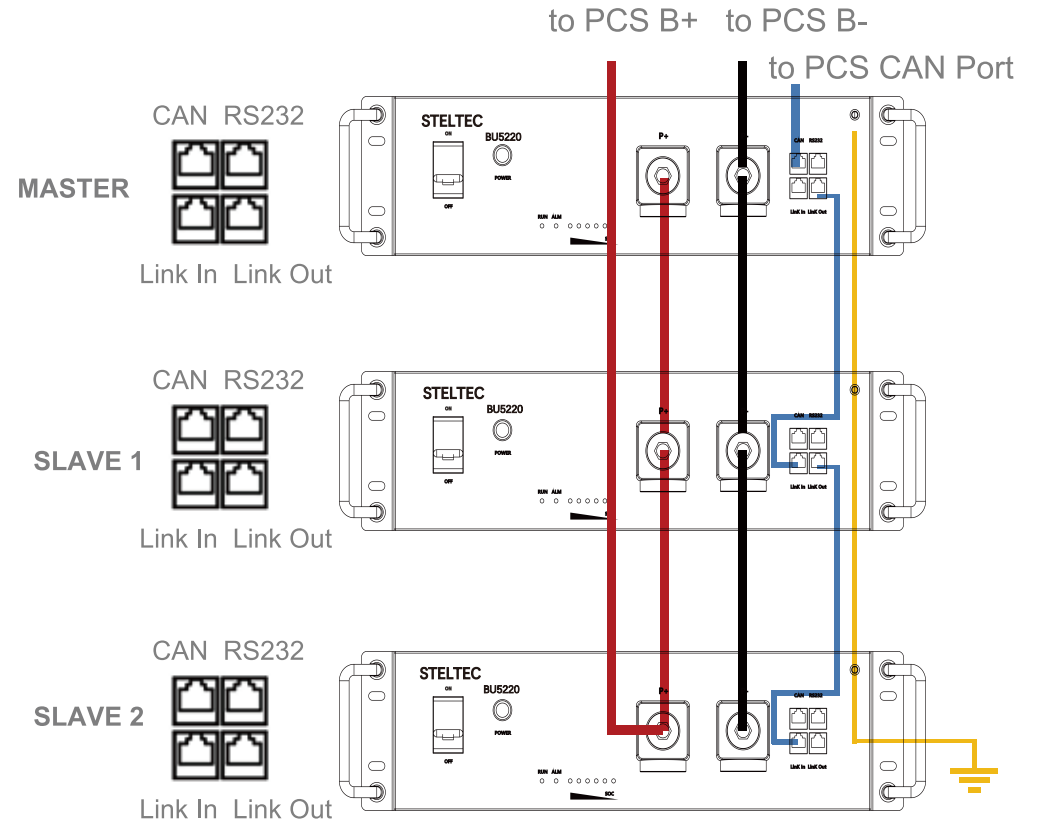

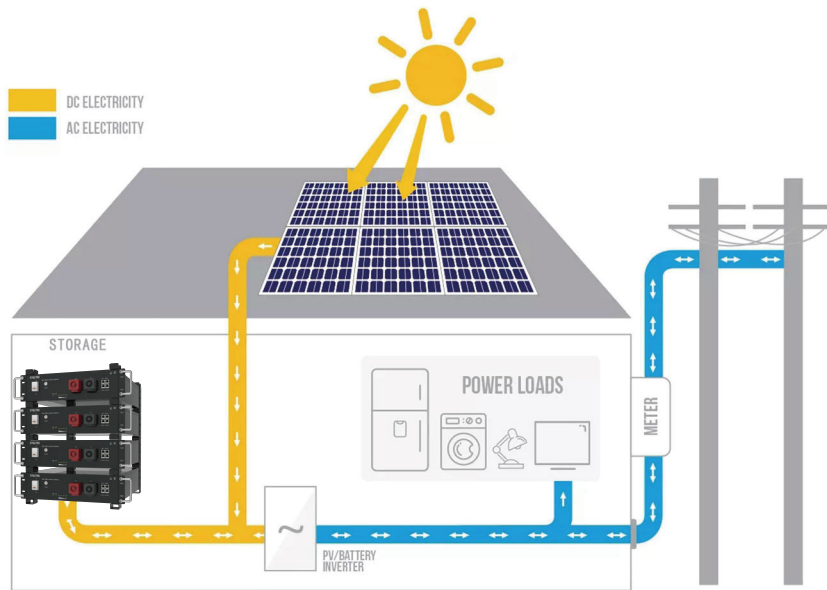

## 5. Commissioning Procedure

After all the cable (power and communication) connections are completed, please ensure the following:

- Ensure the DC switch on the inverter is OFF
- Ensure the AC switch that is connected to the grid and EPS output (if used) of the inverter is OFF
- Ensure the DC switch is OFF

For commissioning we recommend the following steps:

- Turn the DC switch ON
- Refer to section 3.2.1 Start for turning on the battery
- Wait until the LED's on
- Wait until the inverter LED's on
- Turn the DC switch on the inverter ON
- Turn the AC switch that is connected to the grid and EPS output of the inverter ON
- Set-up the battery and the inverter using the App

## 6. MAINTENANCE

### 6.1 Recharge Requirements During Normal Storage

Battery should be stored in an environment with temperature range between  $-10^{\circ}\text{C}$  ~  $+45^{\circ}\text{C}$ , and maintained regularly according to following table with 0.5C (50A) current till 50% SOC after long storage time.

Recharge Conditions When In Storage

Storage Environment Temperature	Relative Humidity of Storage Environment	Storage Time	SOC
Below $-10^{\circ}\text{C}$	/	prohibit	/
$-10\sim 25^{\circ}\text{C}$	5%~70%	$\leq 12$ months	$30\% \leq \text{SOC} \leq 60\%$
$25\sim 35^{\circ}\text{C}$	5%~70%	$\leq 6$ months	$30\% \leq \text{SOC} \leq 60\%$
$35\sim 45^{\circ}\text{C}$	5%~70%	$\leq 3$ months	$30\% \leq \text{SOC} \leq 60\%$
Above $45^{\circ}\text{C}$	/	prohibit	/

### 6.2 Recharge Requirements When Over Discharged

Over discharged (90% DOD) battery should be recharged according to following table, otherwise over discharged battery will be damaged.

Recharge conditions when battery is over discharged

Storage Environment Temperature	Storage Time	Note
$-10\sim 25^{\circ}\text{C}$	$\leq 15$ days	Battery Pack disconnected from PCS
$25\sim 35^{\circ}\text{C}$	$\leq 7$ days	
$-10\sim 45^{\circ}\text{C}$	$< 12$ hours	Battery Pack connected to PCS